

RYCO FILTERS

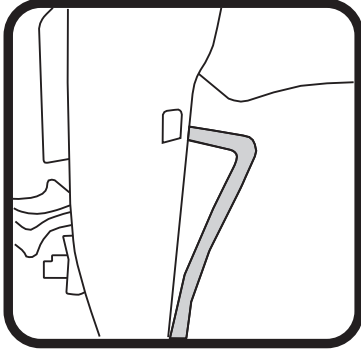

FITTING INSTRUCTIONS FOR RYCO CABIN FILTER RCA145P

HONDA MDX
(Filter is located behind glove box)



1: Disconnect battery ground lead, wait minimum of 3 minutes to allow the air bag backup system to discharge. Remove the stops at both sides of the glove box.

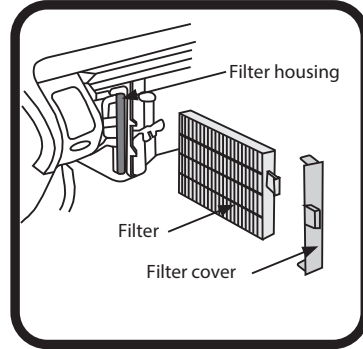

3: Remove the filter cover from housing. Remove used filter and replace with new Ryco cabin air filter. Refit filter cover making sure filter is seated correctly, refit the glove box frame.

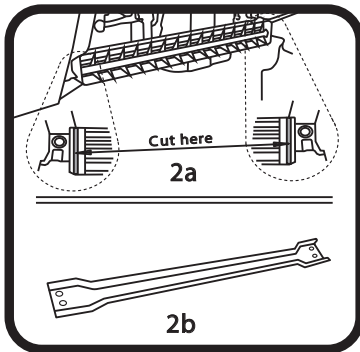

2: Remove the two screws holding the glove box to instrument panel.
2a: Using diagonal cutters, cut the plastic cross piece located at the glove box opening at each end, then discard the plastic cross piece. (Cross piece is not replaced)
2b: Remove the glove box frame retaining bolts and screws, then remove the frame.

4: Re-install stops either side of glove box, Reconnect the battery ground lead, Check for air leaks around filter cover.

Ryco Group Pty Ltd
29 Taras Ave, Altona North
Victoria 3025 Australia.
www.rycofilters.com.au

Ryco Group
A Division of GUD NZ Holdings Ltd
626A Rosebank Road, Avondale
Auckland New Zealand
www.ryco.co.nz