

RYCO FILTERS



FITTING INSTRUCTIONS FOR RYCO CABIN RCA134P FORD MONDEO & COUGAR (Filter is located in engine bay)

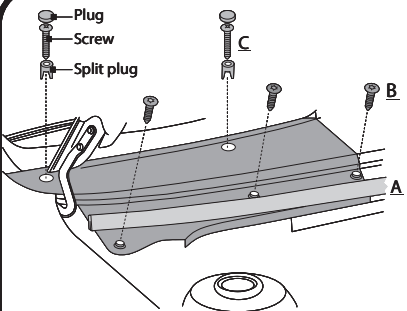

Diagram illustrating the removal of the filter housing. The diagram shows a perspective view of the housing with various components labeled: Plug, Screw, Split plug, C, B, and A. A circular inset shows a detail of a screw. To the right, text instructions describe the removal process.

Lift rubber seal (A) from ridge then remove 3 screws (B), remove 2 caps, 2 screws and 2 split plugs (C), remove cover from vehicle.

♻️ Special tool required to remove 3 screws (B)

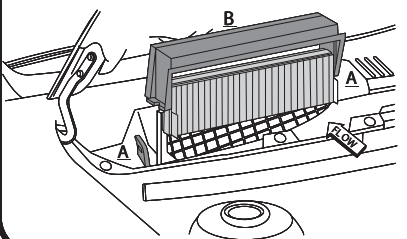



Diagram illustrating the replacement of the filter. The diagram shows a perspective view of the filter housing with a filter element labeled B and clips labeled A. A "FLOW" arrow indicates the direction of air flow. To the right, text instructions describe the replacement process. Below the text is a small icon of a trash bin.

Release 2 clips (A), lift cover (B) to remove, remove used filter from housing and replace with Ryco RCA134P, note direction of air flow. Replace all previously removed components.

Dispose of used filter correctly.



Ryco Group Pty Ltd
29 Taras Ave, Altona North
Victoria 3025 Australia.
www.rycofilters.com.au

Ryco Group
A Division of GUD NZ Holdings Ltd
626A Rosebank Road, Avondale
Auckland New Zealand
www.ryco.co.nz