

X112FW™

X112FW FUEL WATER SEPARATOR FITMENT INSTRUCTIONS

MITSUBISHI TRITON MQ / PAJERO SPORT QE - See RYCO catalogue for specific application details.

The Ryco X112FW kit includes mounting brackets specifically designed for the vehicle, and all components required to complete the installation of Ryco Z980K16 series fuel water separator. It is recommended that the installation is conducted by a qualified mechanic following the procedures in this instruction sheet.



FUEL FILTER
BRACKET
LOCATION

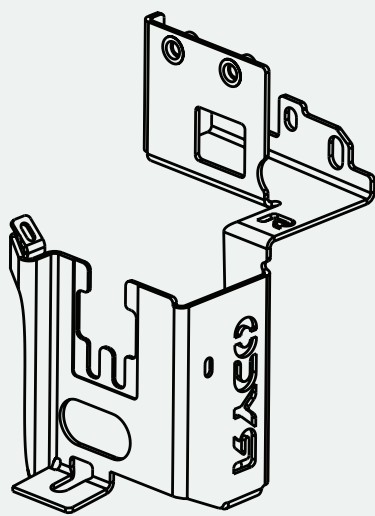

SECTION 1
FUEL WATER SEPARATOR MOUNTING BRACKET



SECTION 2
FUEL WATER SEPARATOR

COMPONENTS INCLUDED IN X115FW KIT

PARTS LIST - FUEL FILTER BRACKET & COMPONENTS BOX

MS4044
CABLE TIE x 20



MS4096A
QUICK CONNECTOR x 2

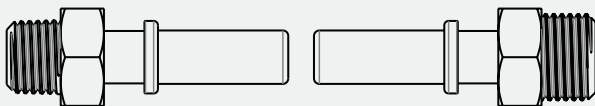

MS4041A
FUEL HOSE CLAMP x 4

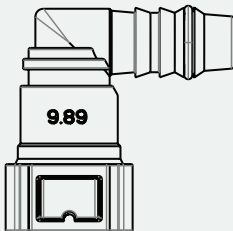
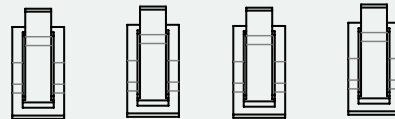

MS4097
ELBOW CONNECTOR x 2

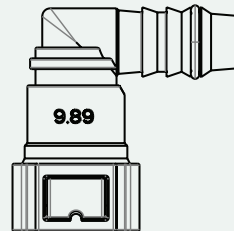

MS4040
FLANGE NUT x 1 (M6)



COMPONENTS INCLUDED IN X112FW KIT

FB9810FC
FUEL WATER SEPARATOR MOUNTING BRACKET x 1

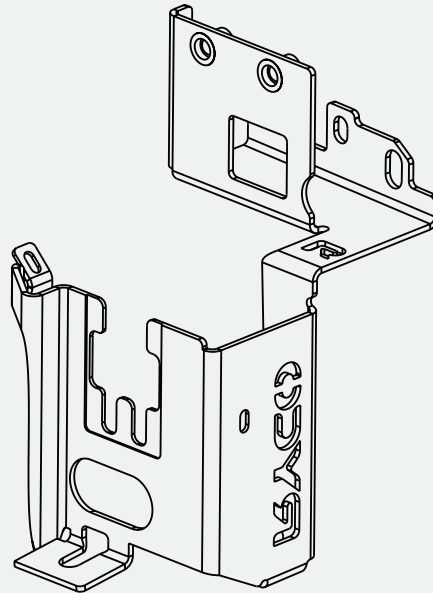

FB9810FC
FUEL HOSE (230mm) x 1

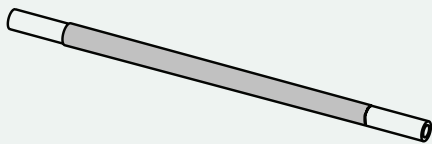

HF9810B
FUEL HOSE (435mm) x 1

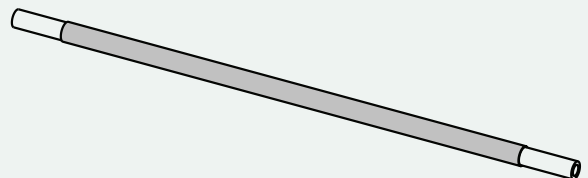

SECTION 1 FUEL WATER SEPARATOR MOUNTING BRACKET FITMENT

PARTS REQUIRED

FB9810FC
Fuel Water Separator Mounting Bracket

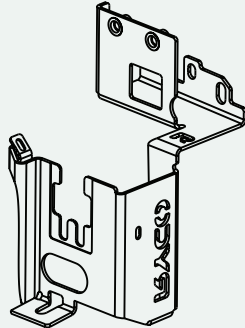

MS4040
Flange Nut (M6) x 1

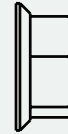

TOOLS & PPE REQUIRED

- Ratchet Set
- Work Gloves
- Socket Set

WORK PROCEDURE

- 1 Unclip all OEM fuel filter Deutsch connectors from the OEM fuel filter bracket.
- 2 Disconnect OEM male & female Deutsch connectors.
- 3 Remove the OEM fuel filter housing from the OEM fuel filter bracket by lifting it up out of its slot, then place it to left hand side of the bracket.
- 4 Unscrew the 2 x OEM M8 bolts shown in FIG. 2A. Ensure you hold onto these M8 bolts, as you will be using these to fit the FB9810FC bracket later.

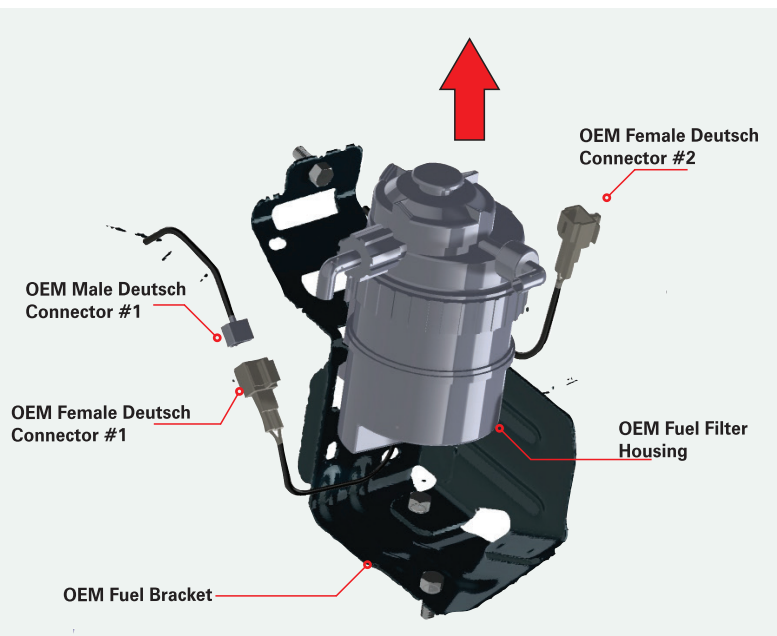

FIGURE 1
OEM FUEL HOUSING REMOVAL

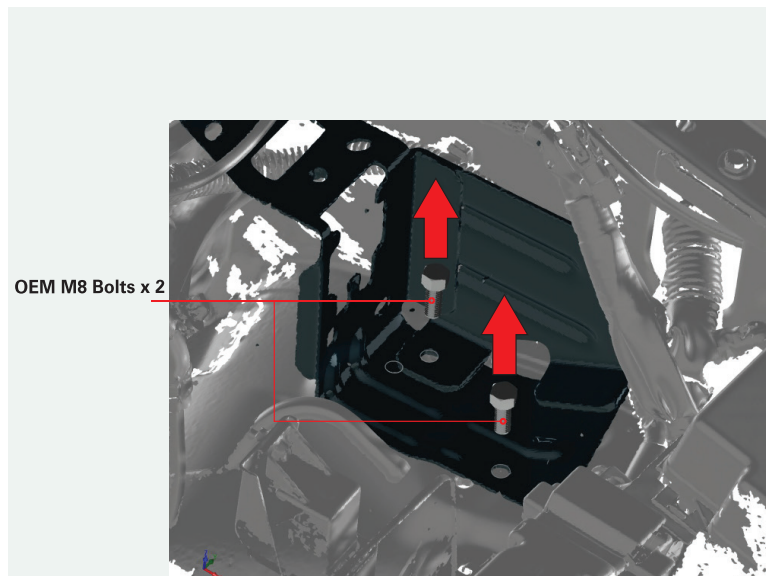

FIGURE 2A
OEM FUEL BRACKET REMOVAL

SECTION 1 FUEL WATER SEPARATOR MOUNTING BRACKET FITMENT

- 5 Unscrew the OEM M8 bolt shown in FIG. 2B. Place this M8 bolt with the other 2 OEM M8 bolts as you will be using these to fit the Ryco FB9810FC bracket later.
- 6 Remove the OEM fuel supply hose & hose clamps (highlighted green in FIG. 3). Have a rag ready as some fuel will spill from the hose and pipe.
- 7 Mount the Ryco FB9810FC bracket using the same mounting points and bolts from the OE bracket you just removed: Half screw in 2 of the OEM M8 bolts in to the base mounting points as shown in FIG. 4A. (Screw in enough to allow Ryco FB9810FC bracket to slide in under the bolt heads).
- 8 Slide the Ryco FB9810FC bracket so bottom two slots of the bracket engage under the OEM M8 Bolt heads.

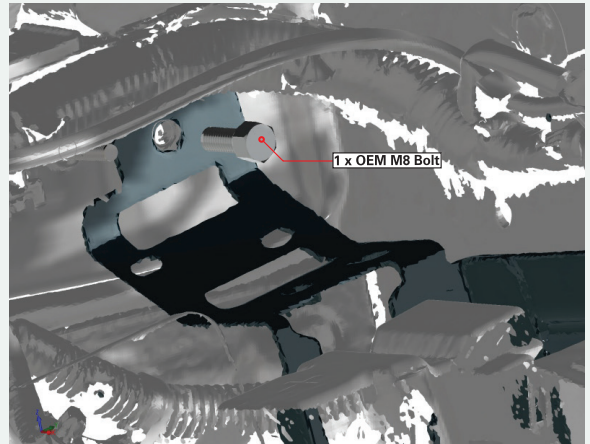

FIGURE 2B
OEM FUEL BRACKET REMOVAL

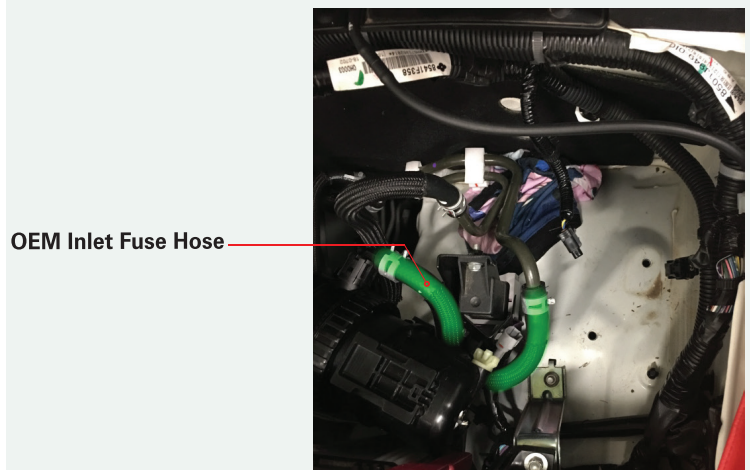

FIGURE 3
OEM INLET FUEL HOSE REMOVAL

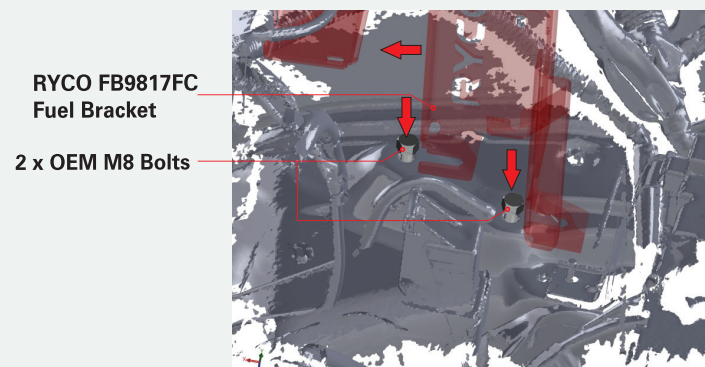

FIGURE 4A
FB9810FC BRACKET INSTALLATION

SECTION 1 FUEL WATER SEPARATOR MOUNTING BRACKET FITMENT

- 9 Screw in the remaining OEM M8 bolt saved from the previous steps into the firewall mounting point. Then install the supplied MS4040 M6 flange nut into the firewall stud as shown in FIG. 4B.
- 10 Proceed to fully tighten the OEM M8 Bolts shown in FIG. 4C.
- 11 Install the OEM Fuel Filter Housing by first passing the female OEM Deutsch connector #1 through the opening as shown in FIG.5A. Then mount the OEM fuel filter housing on to its mounting slot as shown in FIG.5A.

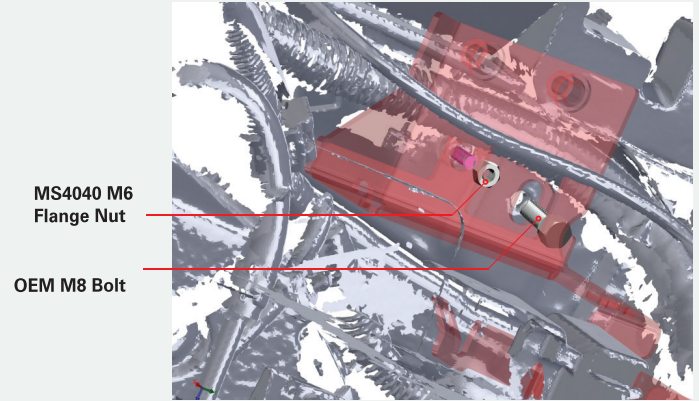

FIGURE 4B
FB9810FC BRACKET INSTALLATION



FIGURE 4C
FB9810FC BRACKET INSTALLATION

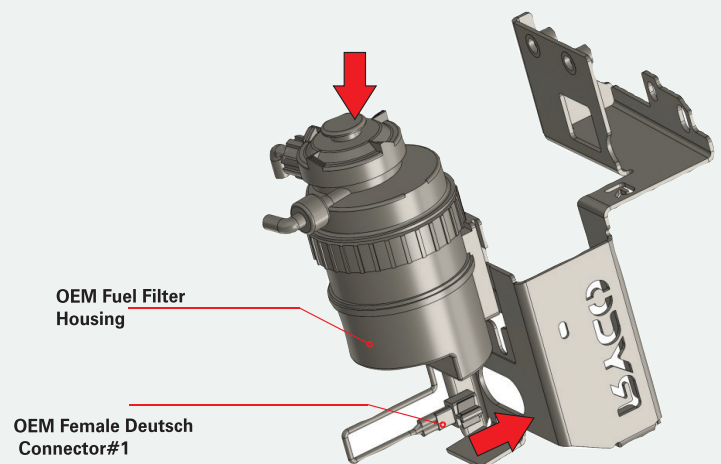

FIGURE 5A
OEM HOUSING INSTALLATION

SECTION 1 FUEL WATER SEPARATOR MOUNTING BRACKET FITMENT

- 12 Clip the female OEM Deutsch connect #1 onto the slot as shown in FIG.5B.
- 13 Connect the male and female OEM Deutsch connector #1 then cable tie the OEM Deutsch connector #1 loom to the slot on the FB9810FC bracket as shown in FIG. 5C
- 14 Clip the female OEM Deutsch connector #2 to the slot on the FB9810FC bracket as shown in FIG. 5C.

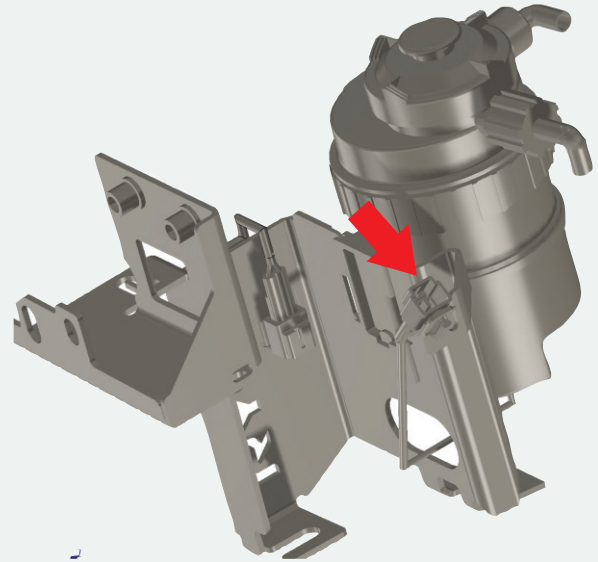

FIGURE 5B
OEM HOUSING INSTALLATION

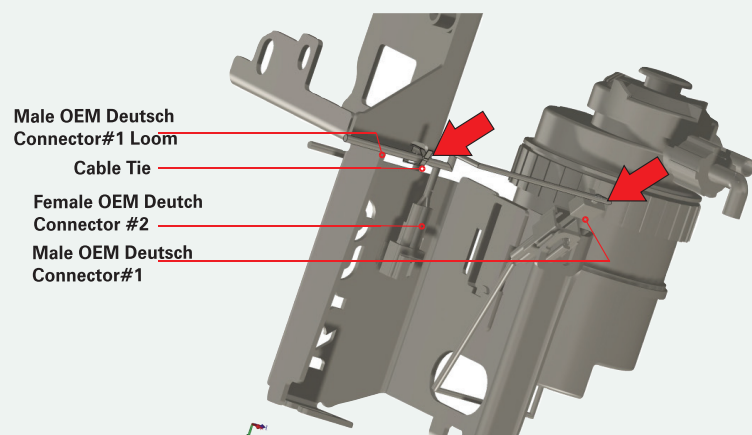
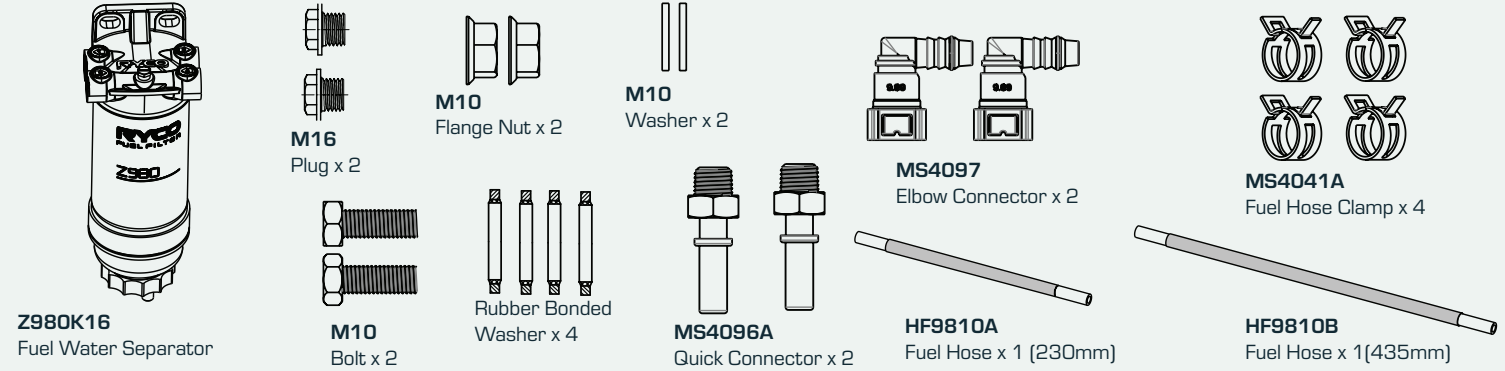

FIGURE 5C
OEM HOUSING INSTALLATION

SECTION 2 FUEL WATER SEPARATOR INSTALLATION

PARTS REQUIRED



TOOLS & PPE REQUIRED

- Ratchet Set
- Work Gloves
- Hose Clamp Pliers
- Rags

WORK PROCEDURE

- 1 Select the supplied male quick connectors (MS4096A) that fit your Ryco fuel water separator head.
- 2 Locate the blanking plugs supplied with your Ryco fuel water separator.
- 3 Install the Ryco fuel water separator head with metal quick connectors, blanking plugs and rubber bonded washers as shown in FIG.6. Tighten blanking plugs (on Port 2 & 3) and quick connectors (on Port 1 & 4).
- 4 Install two (2) supplied elbow connectors onto one end of both the supplied fuel hoses and install four (4) supplied fuel hose clamps onto each end of the fuel hoses, as per FIG. 7. Do not tighten the fuel hose clamps yet.

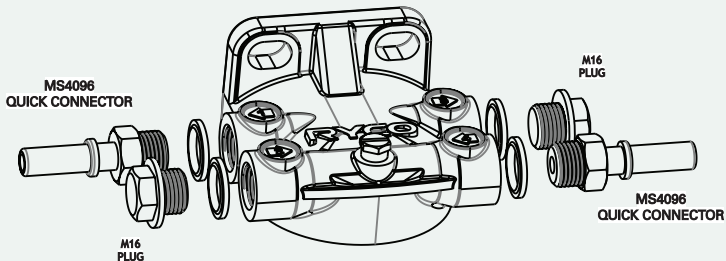

FIGURE 6
FUEL WATER SEPARATOR HEAD PREPARATION

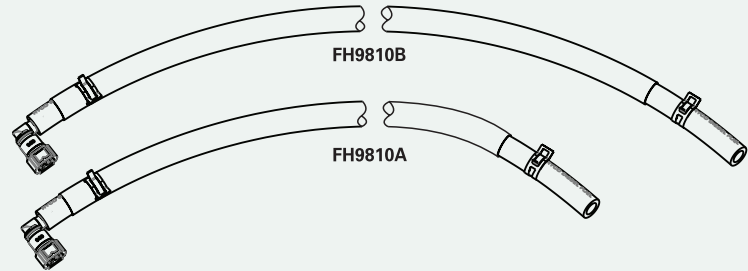

FIGURE 7
FUEL HOSE PREPARATION

SECTION 2 FUEL WATER SEPARATOR INSTALLATION

- 5 Using the M10 Bolts and Washers supplied in the Ryco Z980K16 fuel water separator kit, attach the Z980K16 to the FB9810FC bracket as shown in FIG. 8.
- 6 Starting with the longer Ryco fuel hose FH9810B, install the open end of the hose on to the vehicles fuel tank supply pipe, and tighten with the MS4041A hose clamp as shown in FIG. 9 (overleaf).
- 7 Route the hose around the front of the OE fuel filter housing and along the other side of the fuel filter assembly, shown as green in FIG. 9 (overleaf). Connect the MS4097 Elbow Connector to the Z980K16 Inlet Quick Connector. Connection has been successfully made when you hear a 'click' noise.

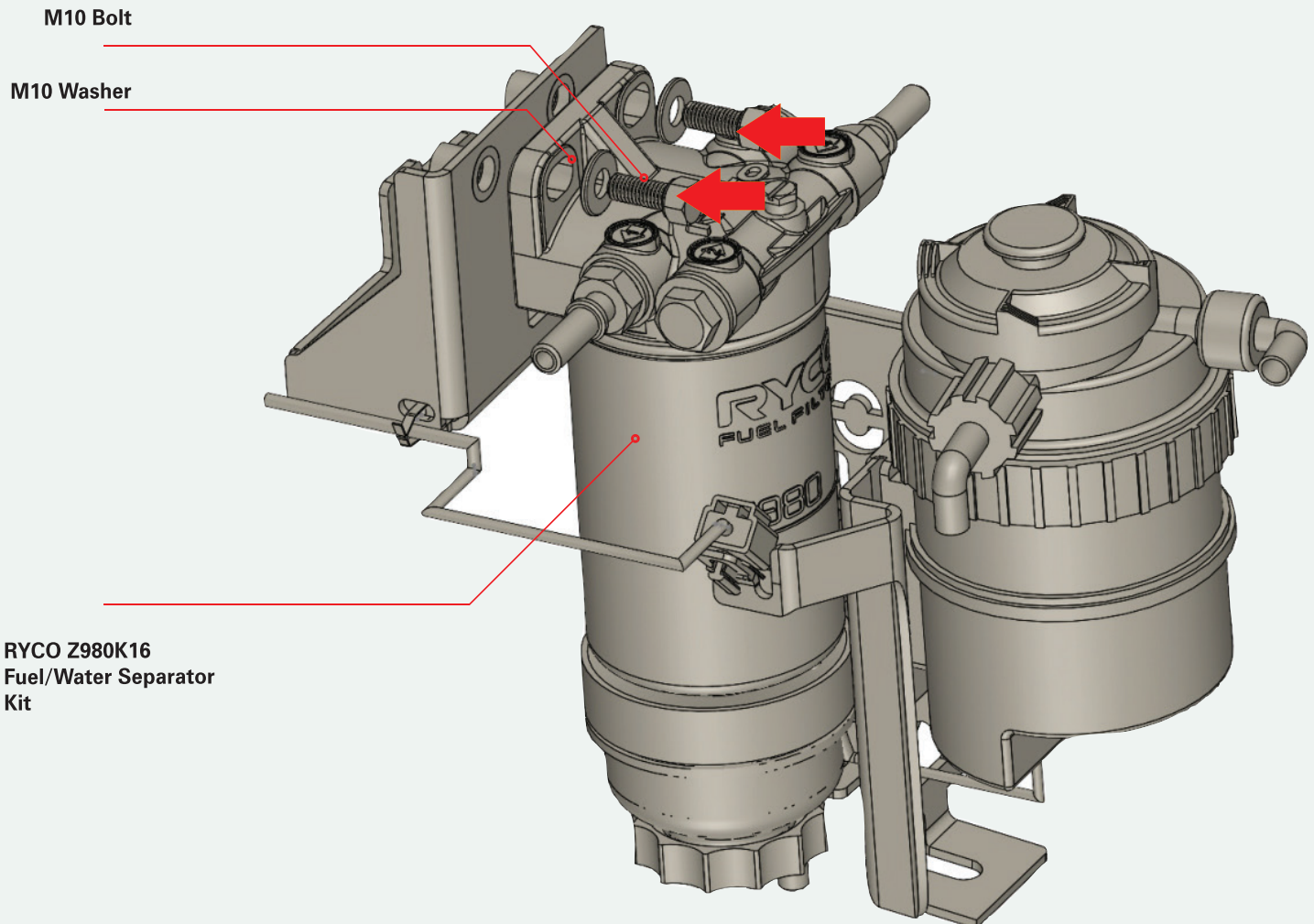

FIGURE 8
RYCO FUEL WATER SEPARATOR FILTER INSTALLATION

SECTION 2 FUEL WATER SEPARATOR INSTALLATION

- 8 With the shorter Ryco fuel hose FH9810A, install the open end of the hose onto the inlet port of OEM fuel filter housing and tighten with the MS4041A Hose Clamp. Route the hose, shown in yellow in FIG. 9. and connect the MS4097 Elbow Connector to the Z980K16 Outlet Quick Connector. Connection has been successfully made when you hear a 'click' noise.
- 9 **WARNING:** The fuel system **MUST BE PRIMED** prior to starting the engine. **DO NOT OPEN THE BLEED SCREW ON THE RYCO Z980K16**, keep closed.
- 10 Locate the priming button on top of the factory fuel filter and prime the fuel system by pumping the button repeatedly. Continue pumping until it is hard to press. The priming process could take approximately 5 - 10 minutes.
- 11 Once you can no longer depress the priming button, turn on the engine. With the engine running, check for fuel leaks on all the installed equipment.

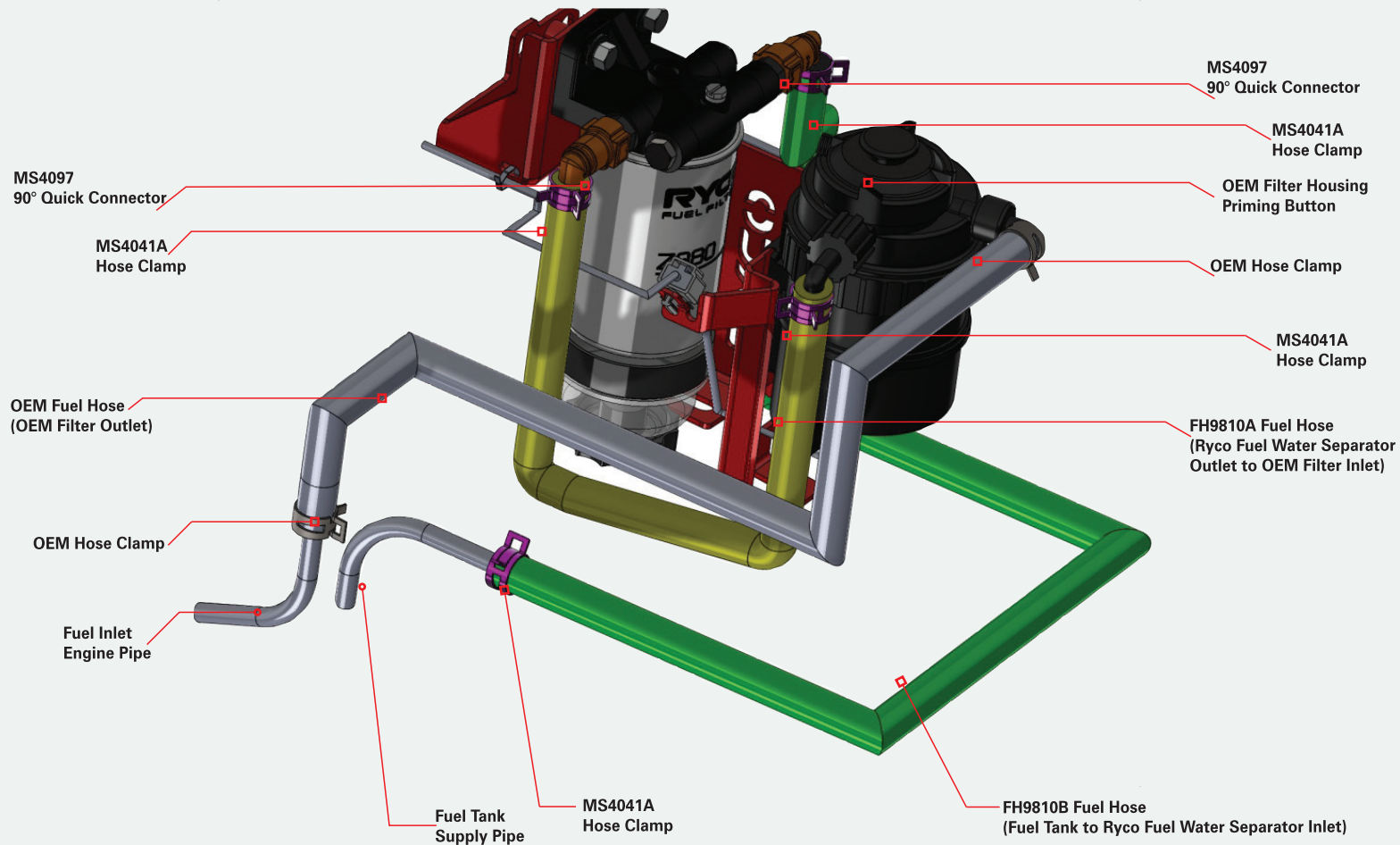

FIGURE 9
FUEL HOSE CONFIGURATION

X112FW™

X112FW FUEL WATER SEPARATOR FITMENT INSTRUCTIONS