

## X103CC™

### X103CC CATCH CAN FITMENT INSTRUCTIONS

**TOYOTA LANDCRUISER PRADO KDJ - See RYCO catalogue for specific application details.**

The Ryco X103CC kit includes mounting brackets specifically designed for the vehicle, and all components required to complete the installation of Ryco RCC351 series Catch Can. It is recommended that the installation is conducted by a qualified mechanic following the procedures in this instruction sheet.



CATCH CAN  
BRACKET  
LOCATION

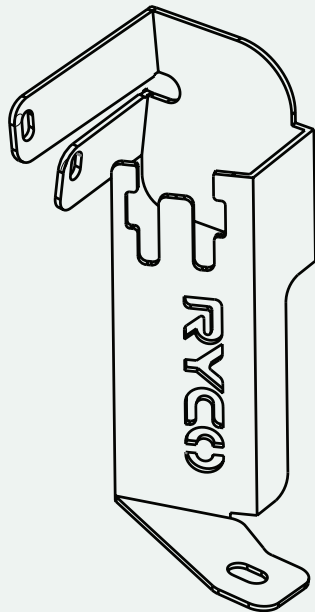

SECTION 1  
CATCH CAN MOUNTING BRACKET

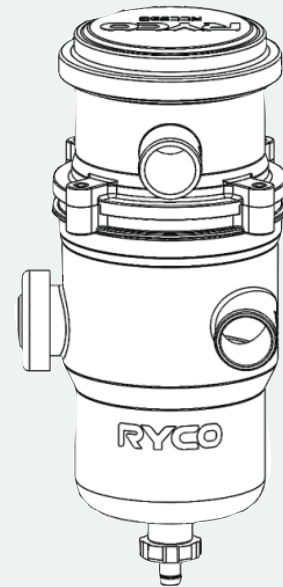

SECTION 2  
CATCH CAN

### COMPONENTS INCLUDED IN X103CC KIT

#### X103CC PARTS LIST CATCH CAN BRACKET & COMPONENTS BOX

MS4089  
PVC HOSE x 1M

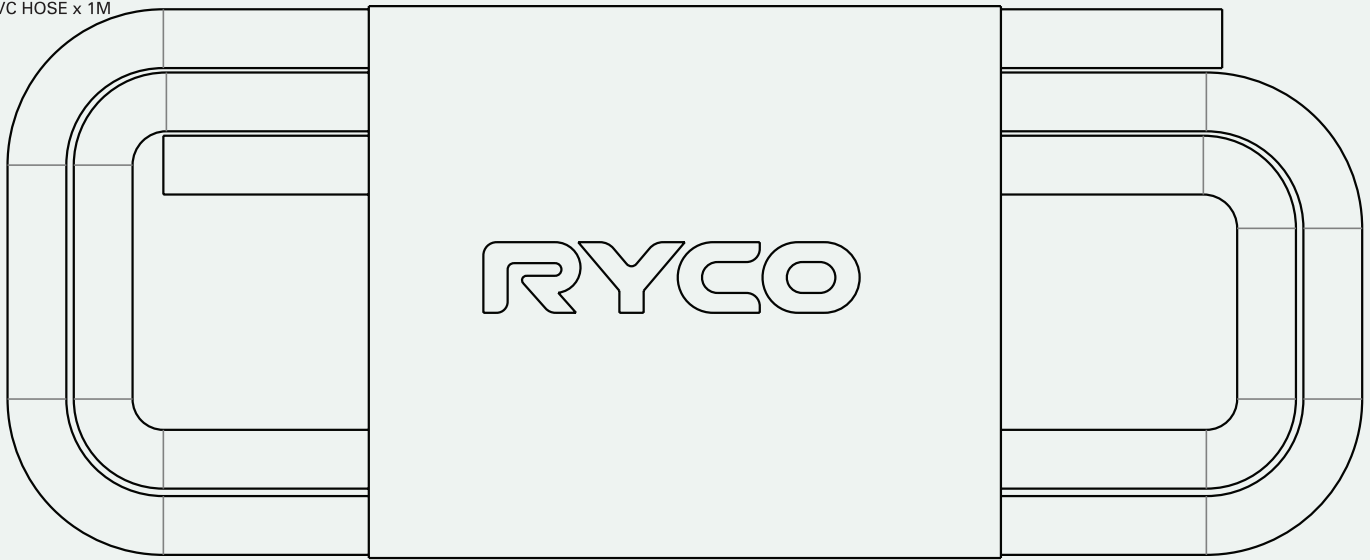

MS4091  
PCV HOSE CLAMP x 2

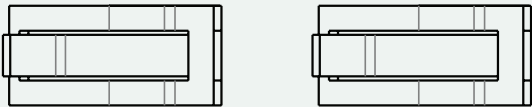

MS4092  
PCV HOSE CLAMP x 2

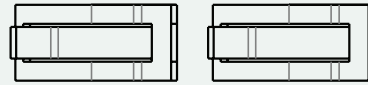

MS4036  
FLAT WASHER x 2 (M6)



MS4037  
HEX BOLT x 2 (M6)

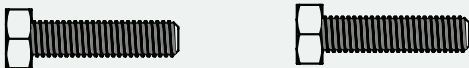

MS4093  
DRAIN HOSE CLAMP x 2

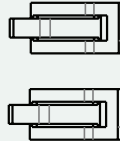

MS4031  
FLAT WASHER x 1 (M8)



MS4099A  
NYLON LOCK NUT x 1 (M8)

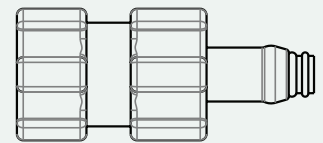

MS4090  
DRAIN VALVE x 1

### COMPONENTS INCLUDED IN X103CC KIT

**FB9804FX**  
CATCH CAN MOUNTING BRACKET x 1

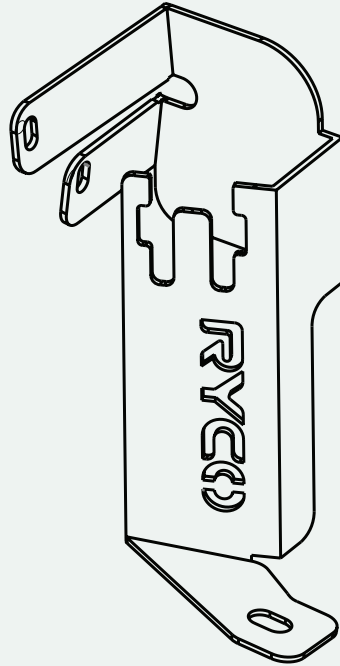

**MH9804X**  
PCV HOSE x 1

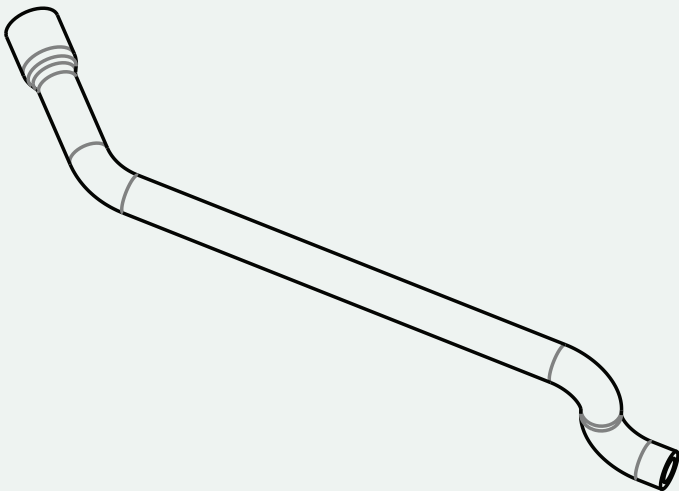

**MH9804Y**  
PCV HOSE x 1

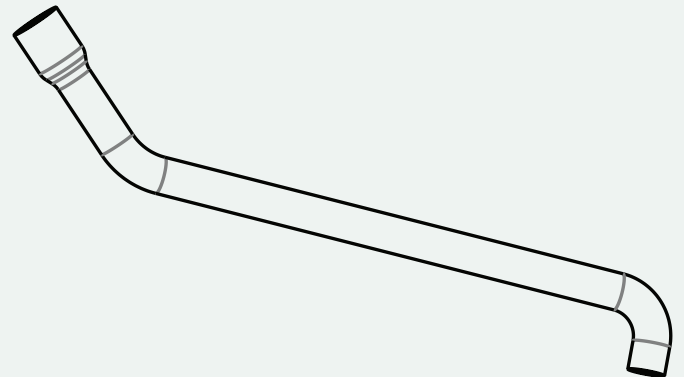

### SECTION 1 CATCH CAN MOUNTING BRACKET INSTALLATION

#### PARTS REQUIRED

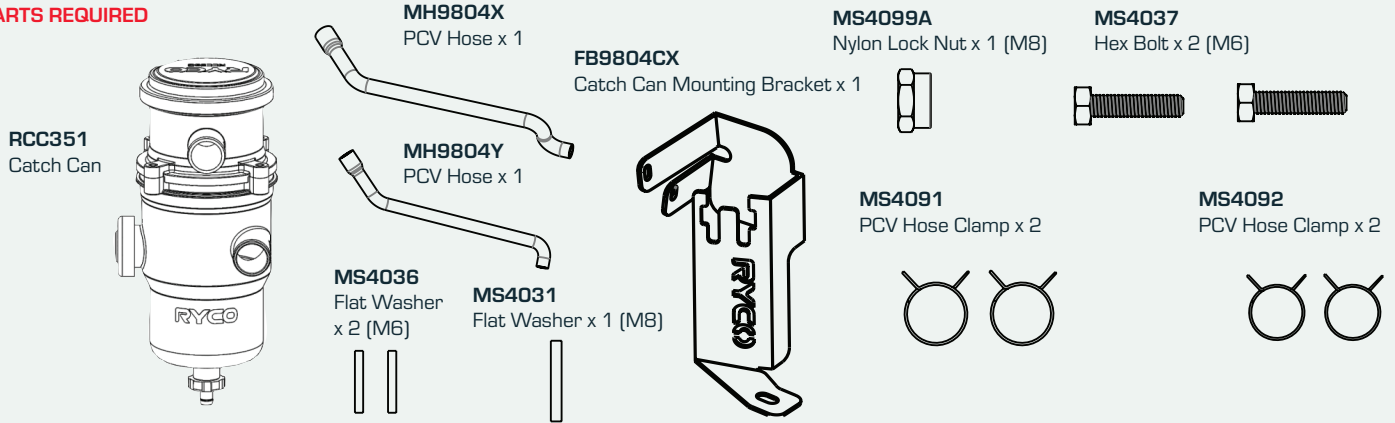

#### TOOLS & PPE REQUIRED

- Ratchet Set
- Work Gloves
- Hose Clamp Pliers

#### WORK PROCEDURE (1/2)

- 1 Remove the plastic engine cover.
- 2 Referring to FIG. 1A Locate stud A in drivers side rear corner of the engine bay.
- 3 Referring to FIG. 1B, Drop FB9804CX Catch Can bracket into engine bay locating engine bay stud A into Catch Can mounting bracket slot A.

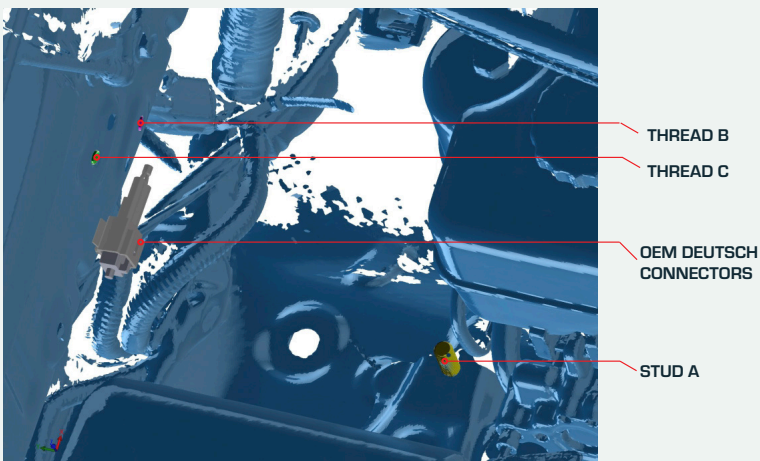

FIGURE 1A  
CATCH CAN BRACKET INSTALLATION AREA

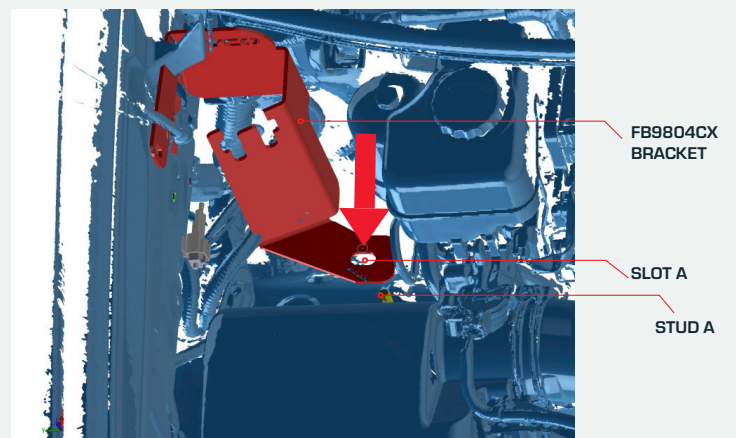
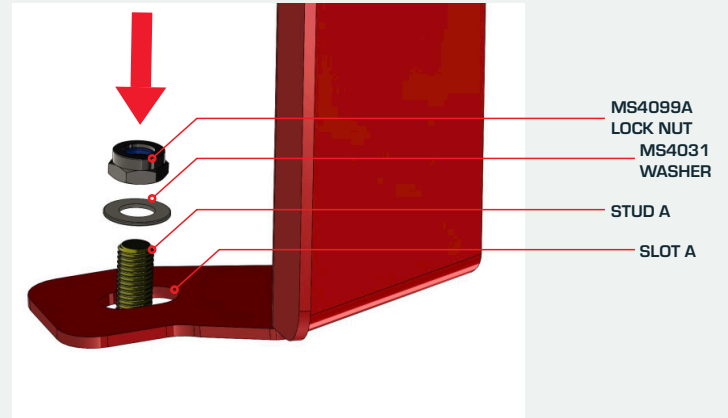

FIGURE 1B  
CATCH CAN BRACKET INSTALLATION

### SECTION 1 CATCH CAN BRACKET INSTALLATION

#### WORK PROCEDURE (2/2)

- 4 Install supplied MS4031 M8 washer onto engine bay stud A, then screw on supplied MS4099A M8 lock nut onto stud A. Refer to FIG. 2A
- 5 Insert supplied 2 x MS4037 M6 bolts through supplied 2 x MS4036 M6 washers, proceed to then screw each of these bolts, through slot B & C, into thread B & C. Refer to FIG. 2B



**FIGURE 2A**  
CATCH CAN BRACKET SLOT A INSTALLATION

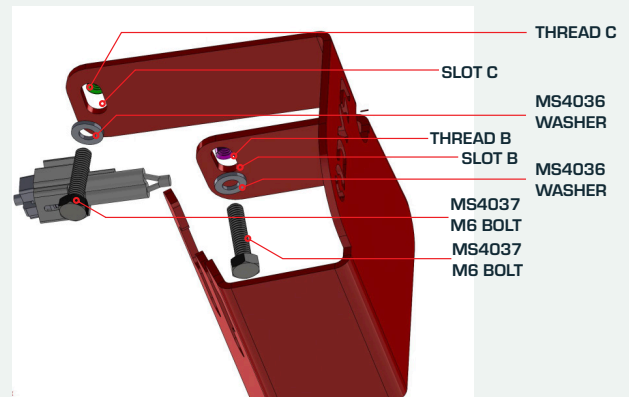

**FIGURE 2B**  
CATCH CAN BRACKET SLOT B & C INSTALLATION

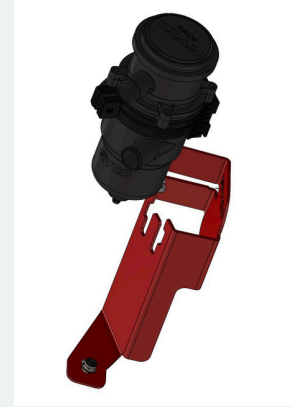

**FIGURE 2C**  
CATCH CAN BRACKET SLOT B & C INSTALLED

### SECTION 2 CATCH CAN INSTALLATION

#### WORK PROCEDURE (1/2)

- 1 Install RYCO Catch Can by inserting nylon bracket slot into slot cut out on FB9804CX bracket, as shown in FIG. 3A & 3B.
- 2 Unclip OEM hose clamp located on OEM PCV hose in engine PCV port location. Proceed to remove OEM PCV hose from engine PCV port, then remove OEM hose clamp from this end of OEM PCV hose. As shown in FIG. 4.



**FIGURE 3A**  
CATCH CAN INSTALLATION



**FIGURE 3B**  
CATCH CAN INSTALLED

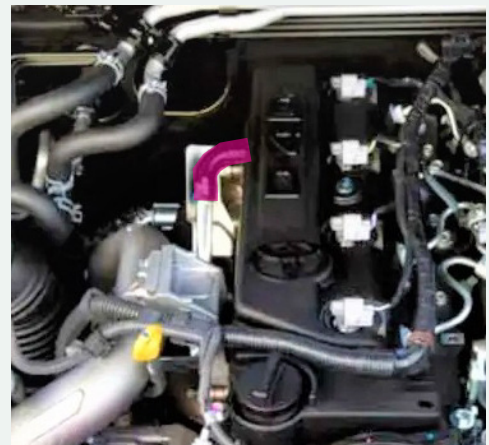

**FIGURE 4**  
OEM PCV HOSE LOCATION

### SECTION 2 CATCH CAN INSTALLATION

#### WORK PROCEDURE (2/2)

- 3 Starting with the MH9804X PCV hose (coloured blue in FIG. 5), install the small end on to the engine PCV
- 4 Install the other end of the MH9804X PCV hose on to the lower, inlet port, of the RCC351 Catch Can and tighten with the MS4091 hose clamp.
- 5 Install the larger end of the MH9804Y hose (coloured green in FIG. 5) on to the upper, outlet port, of the RCC351 Catch Can and tighten with a MS4091 hose clamp. Install the other end of the MH9804Y PCV hose on to the air intake PCV port, then tighten with a MS4092 hose clamp.



FIGURE 5  
FACTORY PCV HOSE



### DRAIN HOSE INSTALLATION PROCEDURE (OPTIONAL)

#### WORK PROCEDURE

- 1 To install the drain hose, remove the drain plug from the bottom of RCC351, take out the rubber seal from the plug and refit. Insert the drain hose and secure it with the supplied spring clamp. Insert the hose drain tap to the other end and use the zip ties to secure the hose. To drain, pull back the red section until all oil has drained out.
- 2 If it has been fitted without using the drain hose supplied, simply slide out the unit from its bracket and loosen the drain plug on the unit and let the oil drain onto a pan or bottle.

